



Fosroc ETIC Solutions for Bearings and Expansion Joints

www.fosroc.com



constructive solutions

ABOUT FOSROC INTERNATIONAL

Since the company's beginnings over 80 years ago, Fosroc has developed into an International leader in delivering Constructive Solutions for projects across a broad range of market segments including transport, utilities, industrial and general buildings.

Fosroc's commitment to customer service and technical support is second to none. We work closely with architects, structural engineers, contractors and owners to best understand their requirements. Together we can develop a bespoke solution for a construction project, adding value and becoming more than just a materials supplier, but a solution provider.

Fosroc has an extensive network of offices and manufacturing locations across Europe, the Middle East, India, North and South Asia, and is further represented in other regions across the world by distributor and licensee partners.

Selecting from the full portfolio of Fosroc products and services and integrating expert technical support, world class customer service and innovation, Fosroc goes beyond just product selling to ensure that we partner with our customers to deliver complete constructive solutions.

- > Admixtures
- > Adhesives
- > Protective Coatings
- > Concrete Repairs
- > Industrial Flooring
- > Grouts & Anchors
- > Joint Sealants
- > Surface Treatments
- > Grinding Aids
- > Waterproofing

FOSROC DELIVER SOLUTIONS NOT JUST PRODUCTS

CAD Details A library of standard CAD details are available, bespoke CAD details can be created for your specific project	Project Specifications Dedicated specification managers on hand to assist with correct system choices and tailored solutions	Site Support Expert product and application support made available from our specialist teams.	Seminar & Training Comprehensive programme of seminars and training courses designed to expand and reinforce your knowledge.
---	--	---	--



TRANSPORT SECTOR PORTFOLIO

FOSROC's vast experience in providing constructive solutions in the transport market sector has been built on a broad portfolio of products. These include waterproof membranes, waterstops, joint sealants, concrete repair mortars, protective coatings, structural strengthening, grouts and concrete admixtures manufactured to the highest quality standards backed by independent test certificates.

At Fosroc we recommend the best technology for each project rather than being driven by one particular response. We liaise and evaluate with our customers the most appropriate solution for what they are trying to achieve. We just want to deliver what

is best to the customer providing peer to peer based solutions for engineering problems to ultimately find a number of ways to create value.

To further enhance our bridge solutions we can now offer a full range of mechanical bridge joints, bearing pads and pot bearings in partnership with European, and long time manufacturer, ETIC. These tried and tested systems have been installed all over the world for a long number of years. For the best bespoke solution for your transport project make Fosroc/ETIC your preferred choice.



Leader in delivering Constructive Solutions
Worldwide!

FOSROC SOLUTIONS FOR BEARINGS AND EXPANSION JOINTS



Mechanical Joints



Elastomeric Bearing Pads



Pot Bearings



transport Solutions

EXPANSION JOINTS

EJ JOINTS

The **Fosroc ETIC EJ** range of toothed mechanical bridge joints comprise of either aluminium or galvanised steel elements manufactured in lengths.

The range is capable of accommodating movements from 85mm up to 300mm resulting from temperature, creep, shrinkage and traffic. The units are supplied in 1m lengths, they are bolted down to the bridge structure using pre-stressed tie bolts which are tensioned under control by using a torque wrench or hydraulic jack.

An elastomeric profile is inserted between the metallic elements to prevent any penetration of water, it is located below the road surface level and is not subject to traffic loading.

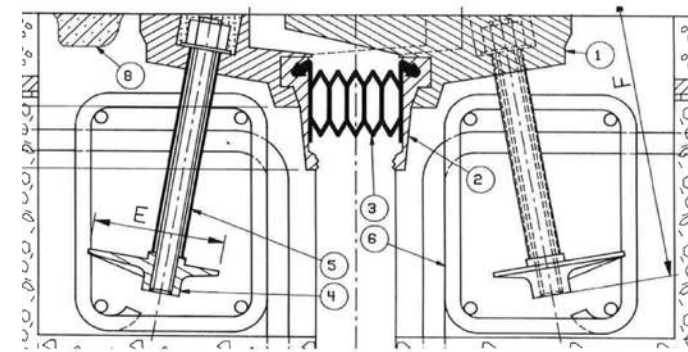

1. Moulded aluminium element
2. Extruded aluminium
3. Elastomeric profile
4. Trefletic anchor
5. Prestressed tie-bolt
6. Additional rebars

ETIPARK JOINTS

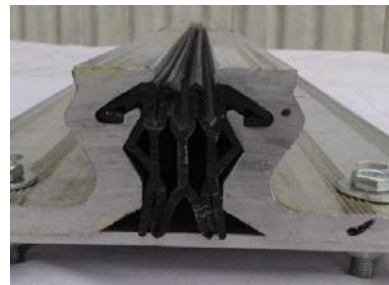

Fosroc ETIC ETIPARK joints are specially designed for car parks, commercial centres and airports. They are capable of resisting traffic and are waterproof.



OMEGA EXPANSION JOINTS



Fosroc ETIC OMEGA joints are designed for movement joints in building structures. They provide a high durable waterproof seal which gives movement accommodation.

The elastomeric neoprene rubber modules are supplied in convenient lengths and are bolted to the structural concrete on either side of the expansion joint.

RAILWAY BRIDGE JOINTS

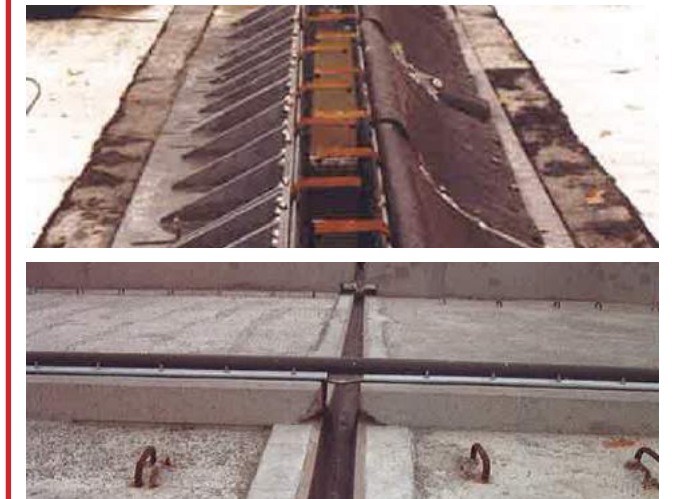

Special bespoke mechanical joints can be fabricated for use on railway bridges using ballast or concrete slab. Contact your local Fosroc office for details.

EJN JOINTS



The **Fosroc ETIC EJN** range of mechanical bridge joints comprise of moulded neoprene elements which are reinforced by steel plates and angles. The neoprene has been formulated to be resistant to oil, grease, salt and sand, it is also resistant to UV and abrasion.

The range is capable of accommodating movements from 30mm up to 330mm resulting from temperature, creep, shrinkage and traffic. The units are supplied in 1m lengths, they are bolted down to the bridge structure using high strength steel anchors. Units are joined together with pre-moulded tongue and groove connections. Kerb and skewed units can be supplied bespoke for each project. **Fosroc Conbextra EP** range epoxy grout is used as a levelling bed, with **Fosroc Nitomortar TS** being applied as the epoxy transition strip between the mechanical joint and the asphalt road surface.

Advantages of Fosroc ETIC EJN mechanical bridge joints

- Capable of horizontal and vertical movement
- No dynamic effect on the bridge structure
- Movement capability up to 330mm
- Versatile for any type of bridge structure
- Waterproof
- Low road noise
- Good corrosion resistance
- Long term durability

COMPRESSION SEALS

The Fosroc ETIC COMPRESS range of compression seals are designed to accommodate movements up to 65mm. The seals are secured to the substrate using adhesive and will absorb longitudinal, lateral and vertical movements



B_1 = Minimum joint gap needed to install the seal (dependent on temperature)
 H_1 = Minimum joint depth needed for correct functioning.

Product Name	Profile Dimensions			Movement capacity (mm)	Joint Gap		Min. Dimensions at installation		Weight (kg)
	Width B (mm)	Height H (mm)	Length L (m)		min (mm)	max (mm)	B ₁	H ₁	
COMPRESS A 21-22	36	35	30	12	18	30	21	45	0.5
COMPRESS A 25-20	46	37	30	20	20	40	25	50	0.8
COMPRESS A 36-22	56	55	20	22	27	49	36	65	1.4
COMPRESS A 45-30	68	70	20	30	30	60	45	85	2.4
COMPRESS A 55-35	80	87	20	35	35	70	55	100	3.7
COMPRESS A 70-45	107	90	12	45	50	95	70	110	4.7
COMPRESS A 90-65	135	100	12	65	55	120	90	130	5.7



BEARINGS - ELASTOMERIC PADS

Fosroc ETIC ETIBLOC bearing pads consist of an elastomeric block composed of either modified neoprene or natural rubber in which parallel and plane steel reinforcement plates are totally embedded before vulcanization.

The vulcanization (treatment at high temperature and under pressure) gives the elastomer its mechanical characteristics and ensures the perfect bonding of steel and rubber. Full protection of the steel reinforcement from corrosion is assured.

These elastomeric bearing pads provide an economical solution to problems caused to a structure by static and dynamic effects of traffic or wind / variations of temperature, creep, shrinkage or pre-stressing / vibrations and impacts. The pads provide freedom between two elements of a bridge structure absorbing stresses from horizontal and vertical loads and rotations.

Quality control is carried out on both material and finished product. An internal control is conducted at each stage of production along with independent inspection of manufacturing process and checking.

These stringent quality assurance controls ensure that our finished product is delivered to site as per designed specification requirements.

For large displacements, a sliding elastomeric pad Fosroc ETIC ETI-G using a PTFE sheet can be used.

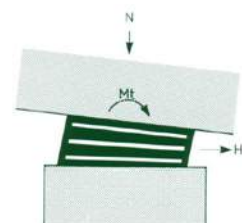

- Vertical loads deflection (N)
- Horizontal loads and displacements
- Rotations (Mt)
- (refer to the table opposite)

Dimensions (W x L x H) mm	Vertical Load (min to max) KN	Displacement (mm)	Rotation angle Width arc/rad	Rotation angle Length arc/rad
100 x 150 x 14	30 to 150	7	0.0088	0.004
150 x 200 x 14	60 to 400	7	0.0036	0.0021
200 x 300 x 19	120 to 750	9	0.005	0.0023
250 x 300 x 19	150 to 1100	9	0.0031	0.0022
250 x 400 x 19	200 to 1500	9	0.0031	0.0013
300 x 400 x 19	240 to 1800	9	0.0021	0.0013
400 x 500 x 24	700 to 3000	11	0.0029	0.0015
400 x 600 x 24	840 to 3600	11	0.0022	0.001

Each elastomer bearing pad has several thickness options. Please refer to your local Fosroc Office for a list of full range. Fosroc ETIC ETIBLOC bearing pads are also available without steel reinforcement plates for less critical applications. Please contact your local Fosroc office for details.



BEARINGS - STEEL POTS

Fosroc ETIC POTETIC pot bearings, although relatively small in size can transmit considerable loads from the bridge structure, absorb rotations and accommodate horizontal movements.

They are mainly composed of a steel pot with an elastomeric pad and steel lid. The elastomeric pad is totally insulated within the pot through interposition between the pot and the lid of an anti-extrusion joint. When subjected to vertical and horizontal loads, the pot acts as an incompressible fluid so that it enables an oscillation of the lid in relation to the pot; the hydrostatical pressure being released.

Fosroc ETIC POTETIC pot bearings are available in 3 grades covering all movement, rotation and sliding permutations. This extensive range coupled with Fosroc/ETIC excellent technical experience and service ensures that the best fit pot bearing can be chosen for each project.

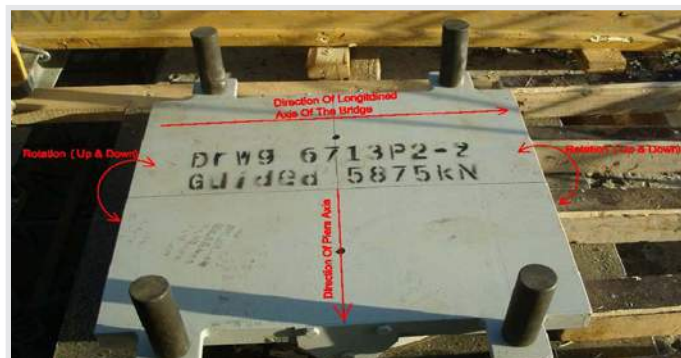

Three grades of pot bearings:

- Fixed
- Guided
- Free

Fosroc ETIC POTETIC pot bearings are manufactured as bespoke for each project ensuring that the correct choice and design is utilised for each and every pot bearing location within the project. They are manufactured to high quality assurance procedures, utilising the best possible materials.

Once loadings, rotations, movements and approximate sizes are given then Fosroc/ETIC can determine the correct pot bearing required. CAD drawings for installation are also supplied. Installation of the pot bearings is straightforward, full method statements are available. Each pot bearing is anchored, levelled and grouted using **Fosroc Conbextra EP** range high strength epoxy free-flowing grout.





Aggressive environmental conditions can cause steel reinforcement corrosion within the bridge structure's concrete resulting in delamination and spalling of reinforced concrete members, which if not resolved can lead to a deterioration in structural strength. Fosroc's comprehensive **Renderoc** range of concrete repair products can cater for any repair need, and if a full reinstatement of a protective barrier coating is required then products are available from the **Dekguard** range.

Carbon-fibre structural strengthening systems can be utilised if required, a full portfolio of types are available from the **Nitowrap** range.



Foundations / retaining walls / abutments can be protected against water and/or chemical attack from within the ground soil with Fosroc's premium waterproofing system **Proofex** range.

For less aggressive conditions Fosroc offer a full range of **Nitoproof** liquid-applied coatings.



Where pre-stressed post-tensioned bridge segments are used these segments must be adhered with high quality bonding adhesive.

Fosroc **Nitobond SBA** epoxy resin has been specially formulated for this purpose giving excellent adhesion, high strength and non-sag performance.

TRANSPORT SOLUTIONS

From waterproofing of soffits, piers and parapets, Fosroc have a wide range of solutions that will meet your needs, ensuring that your bridge structure will stand the test of time. A long track record in the Middle East and Gulf Regions positions Fosroc as the supplier of choice with proven product solutions, experienced specification assistance backed with excellent customer service.

Fosroc understands that ease and simplicity of application are important factors. All our bridge solution products are supported by detailed technical literature, giving method statements and requirements before, during and after application. In addition, by partnering with our customers at all stages, we aim to give full support adding value as well as providing the best possible project solution with long term benefits.



System type	Example of application use	Fosroc Product name
Protective Coatings	Piers, soffits, abutments	Fosroc Dekguard S and E2000
Grouts	Bridge bearings	Fosroc Conbextra EP range and BB80
Cable Grouts	Post tensioned/Pre stressed cables	Fosroc Cebex and Conbextra Cable Grout
Bonding Adhesive	Bridge segments	Fosroc Nitobond SBA
Joint Sealants	Expansion joints	Fosroc Colpor 200 and Nitoseal MS300
Structural Strengthening	Piers, soffits, abutments	Fosroc Nitowrap range
Concrete Repair	Piers, soffits, abutments	Fosroc Reneroc range
Waterproofing	Foundations	Fosroc Nitoproof and Proofex range

Fosroc offers a full range of construction chemical solutions, helping to protect structures throughout the world. Please refer to our brochures, which include:

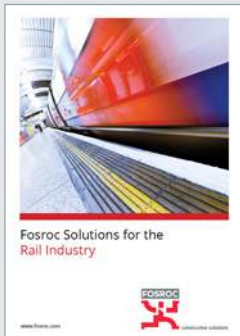
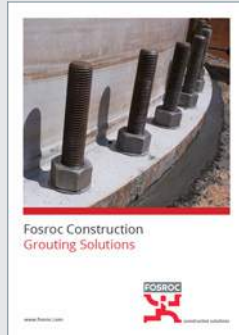

Details of your local Fosroc office can be found at www.fosroc.com

Important Note

Fosroc products are guaranteed against defective materials and manufacture and are sold subject to its standard terms and conditions of sale, copies of which may be obtained on request. Whilst Fosroc endeavours to ensure that any advice, recommendation, specification or information it may give is accurate and correct, it cannot, because it has no direct or continuous control over where or how its products are applied, accept any liability either directly or indirectly arising from the use of its products, whether or not in accordance with any advice, specification, recommendation or information given by it.



constructive solutions